

# CHARACTERISTICS CURVE P2

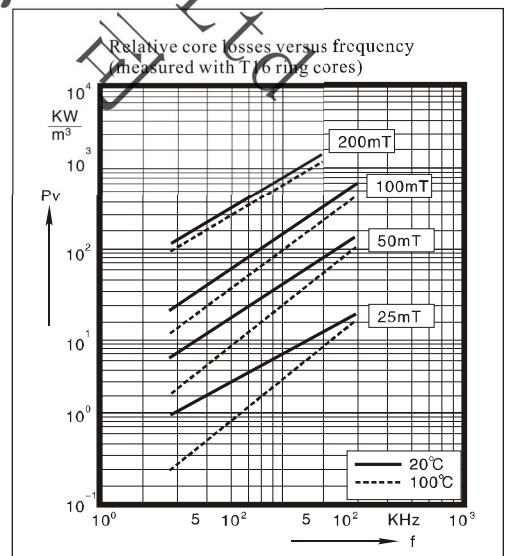

# CHARACTERISTICS CURVE P3

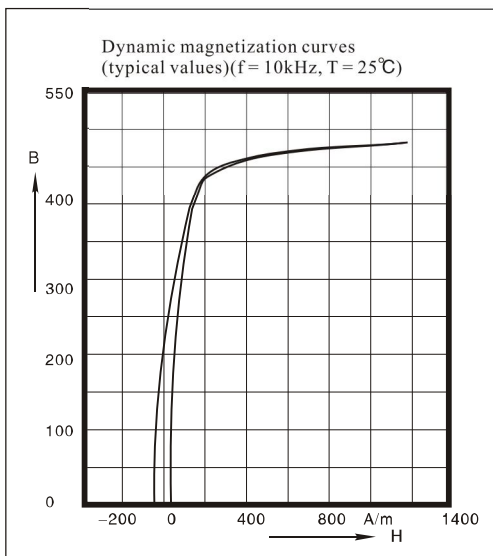
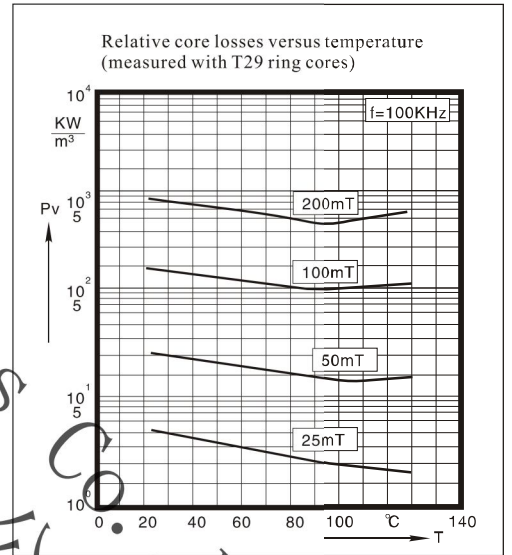
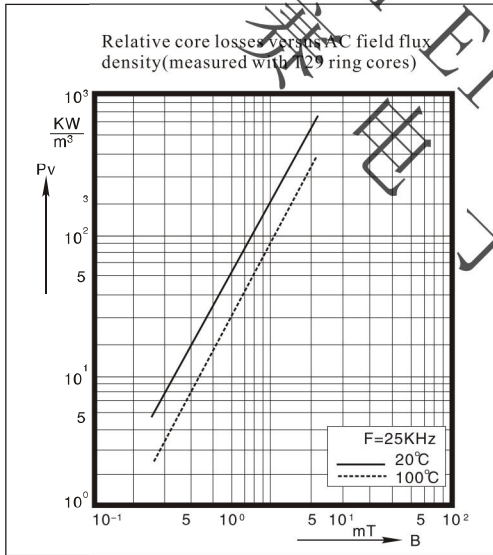
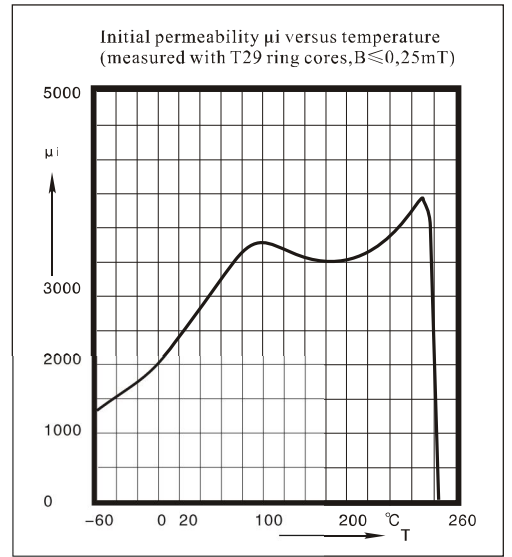
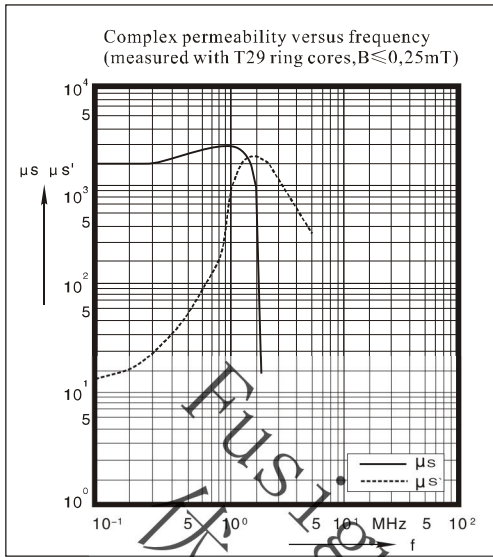
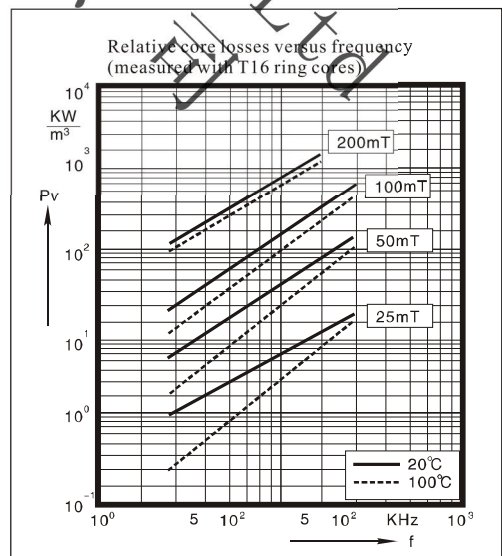
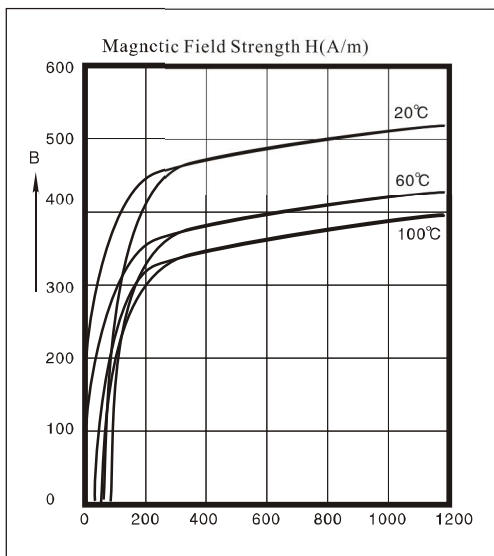
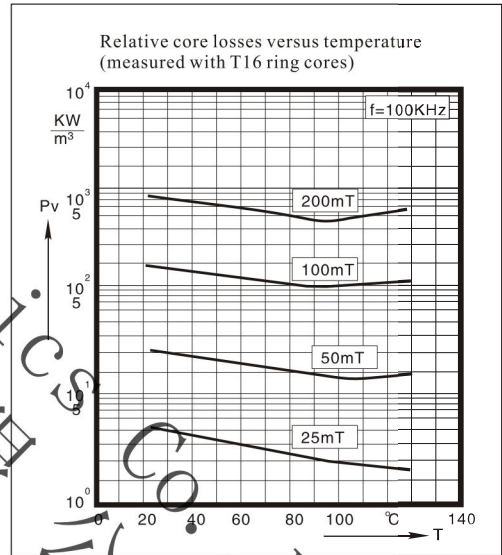
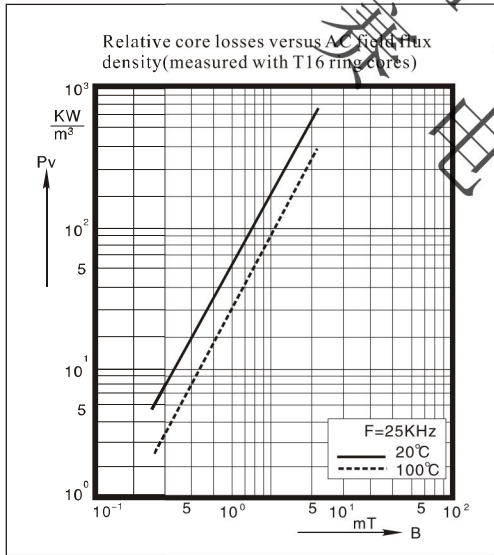
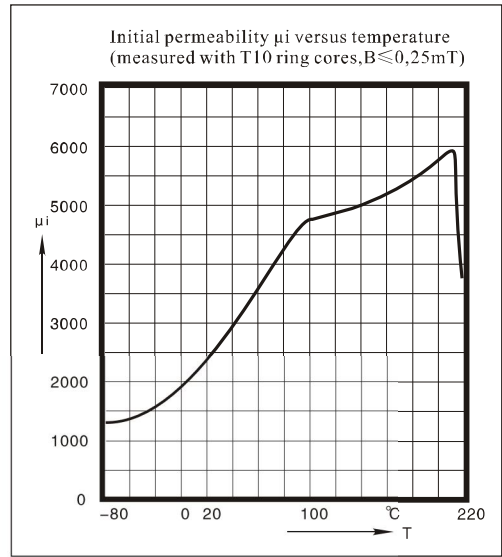
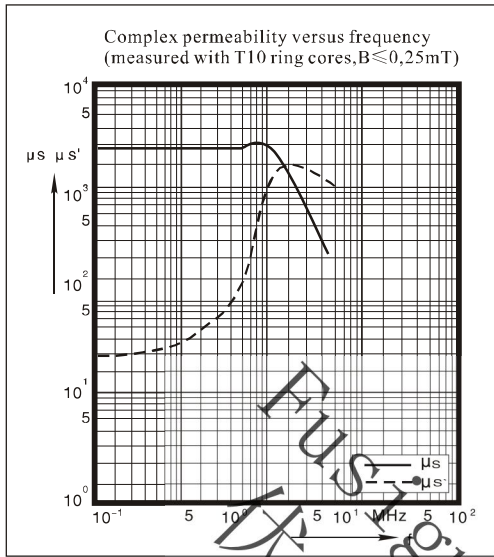

# CHARACTERISTICS CURVE H6K

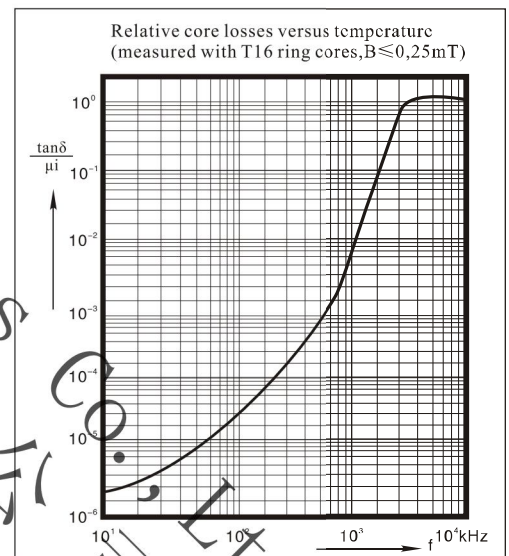
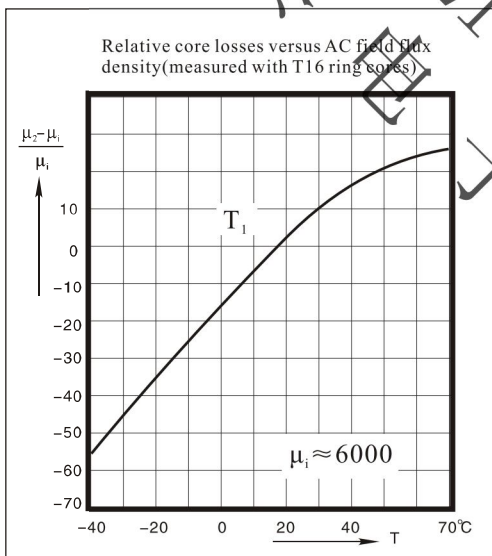
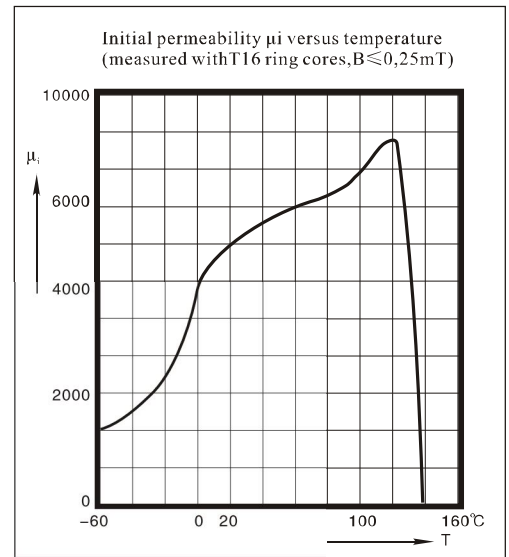
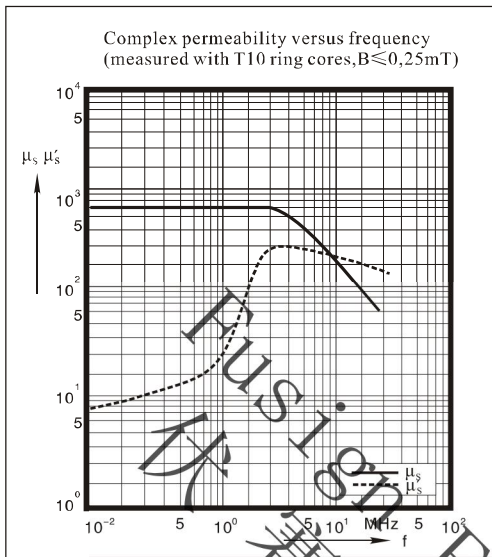

# CHARACTERISTICS CURVE H7K

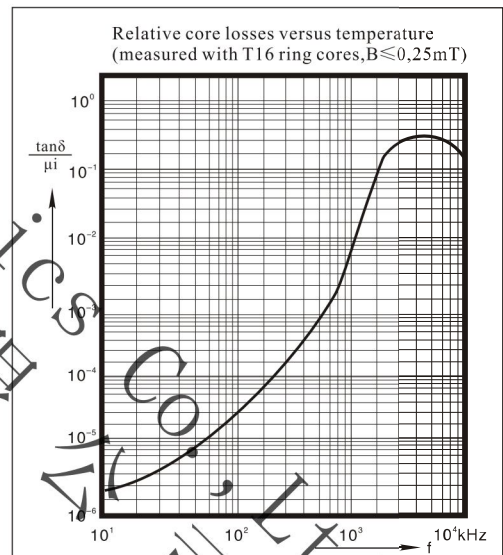
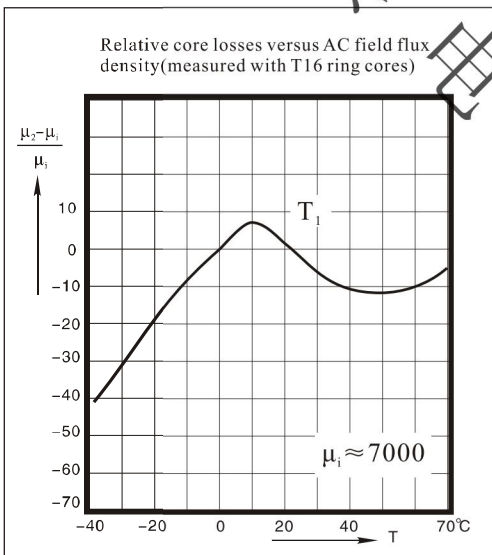
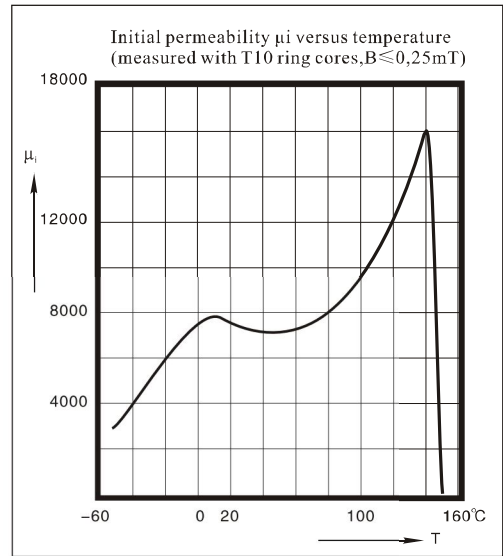
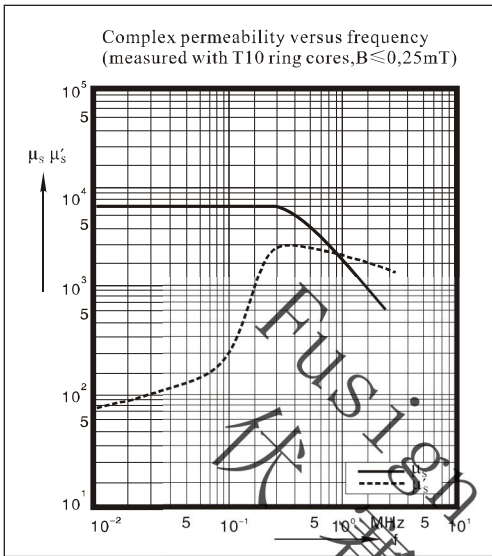

# CHARACTERISTICS CURVE H10K

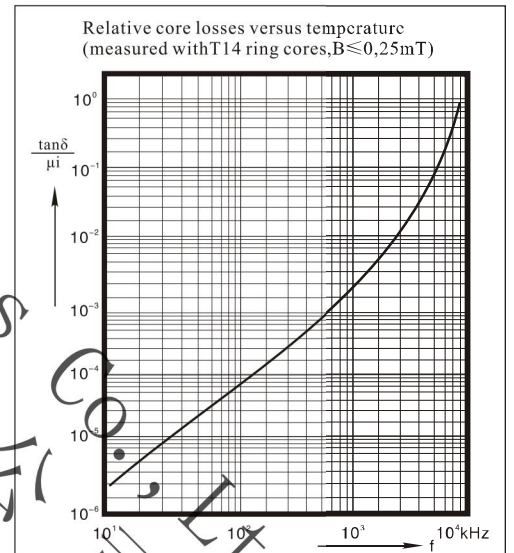
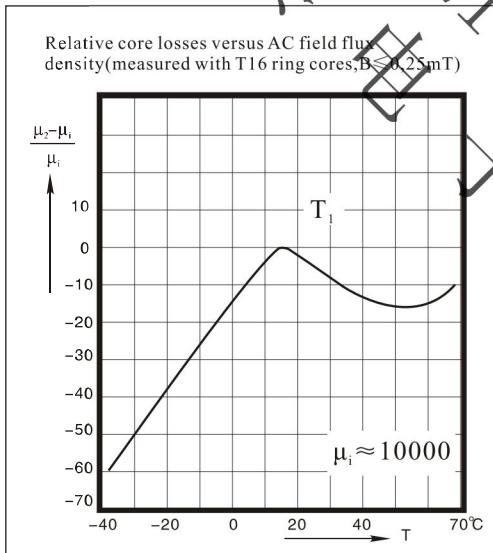
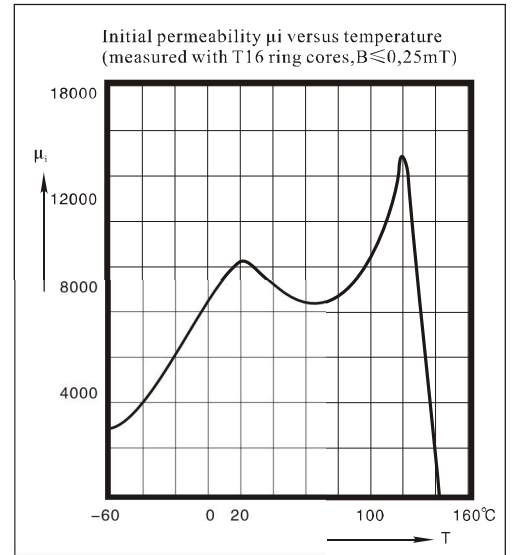
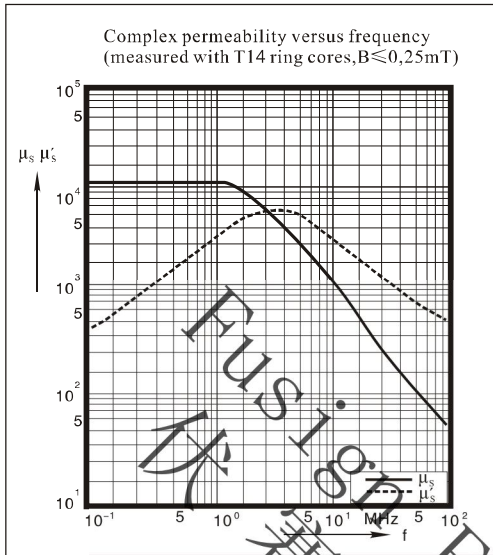

# CHARACTERISTICS CURVE H15K

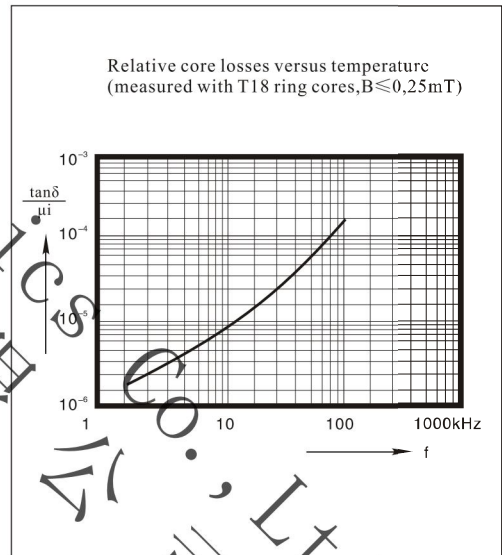
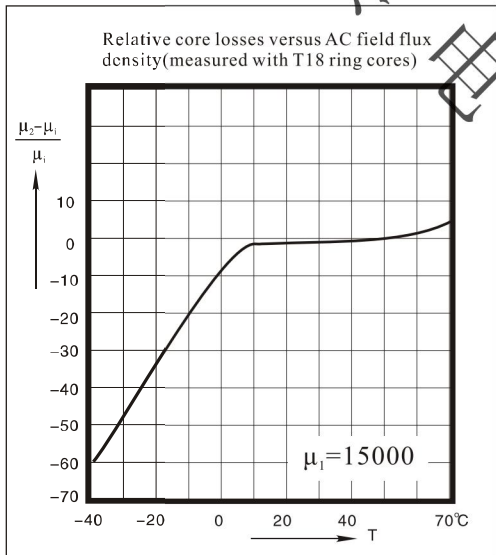
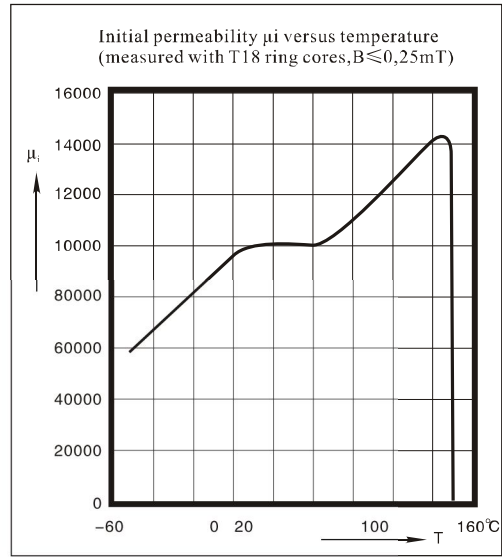
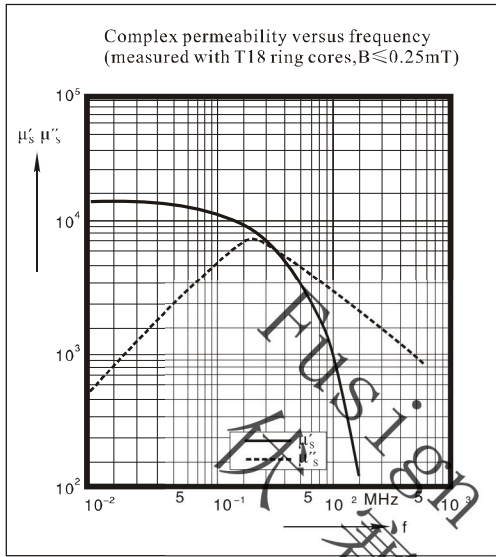

# CHARACTERISTICS CURVE HQ2K

